

TZ THT-03R Temperature and humidity transmitter

User Manual V1.1



1.Overview

The THT-03R temperature and humidity transmitter is designed based on the RS-485 communication interface, compatible with the standard Modbus-RTU protocol, and can be connected to the Modbus network to achieve temperature and humidity measurement and monitoring.

The THT-03R sensitive element uses SHT30, a newly designed CMOSens chip, an improved capacitive humidity sensor element and a standard energy gap temperature sensor element. Its performance has been greatly improved and even exceeded the previous generation of sensors (SHT1x and SHT7x.) Reliability level to make its performance in high humidity environments more stable.

THT-03R adopts the DIP switch to set the address method, which avoids the need to use the upper computer to set the address in advance, and is simple, convenient and easy to maintain and replace.

THT-03R adds a display screen and indicator lights, users can more intuitively see the current temperature and humidity data and machine status.

THT-03R has excellent long-term stability, low latency, low power consumption, strong resistance to chemical pollution and excellent repeatability. It is used for accurate temperature and relative measurement in HVAC, communication equipment rooms, warehouse buildings and automatic control applications. The ideal solution for humidity.

2.Feature

- Low power consumption
- Fully calibrated
- High precision and good consistency
- Long-term stability, low drift
- Humidity full range temperature compensation
- Standard Modbus-RTU protocol
- Strong interface defense capability and stable communication

3.Application field

Generally used in indoor clean environment, such as:

- HVAC
- Building automation
- Laboratory, hospital, library
- Storage and production facilities in the pharmaceutical, paper, food and electronics industries

4. Technical data

4.1 Power supply

Supply voltage	DC 5~36V
Current	5mA

4.2 Display and indicator

Display screen	Keep the power on, the screen will be bright, and the temperature and humidity display are accurate to one decimal place
Indicator light	Keep the power on, it will be red, and it will flash once when reading the data.

4.3 Transfer Protocol

Transfer Protocol	485 port, standard modbus, rtu
-------------------	--------------------------------

4.4 Transmission rate

Transmission rate	4800bps / 9600bps
-------------------	-------------------

4.5 Transmission distance

The standard maximum transmission distance is about 1200 meters (depending on the use environment, transmission material and transmission rate)

Number of theoretical nodes	32
-----------------------------	----

4.6 Temperature parameter

Sensing element	SHT30
Measuring range	-40~120°C
Resolution	0.1°C
measurement accuracy	±0.2°C

4.7 Humidity parameters

Sensing element	SHT30
Working range	0~95%RH
Resolution	0.1%RH
Measurement Accuracy	±2%RH
Hysteresis	< ±0.8%RH
Response time	About 8s (from 33%RH to 75%RH, in flowing air)
Long-term stability	<±0.25%RH/year (under no pollution)

4.8 Environmental conditions

working environment	-40~85°C / 0~100%RH(Non-condensing)
Storage environment	-40~85°C / 0~100%RH(Non-condensing)

4.9 Electrical connections

Label	Function description
B	Terminal B of RS485 interface
A	Terminal A of RS485 interface
GND	Public ground (connect to the negative end of the power supply when DC power is supplied)
VCC	Power supply positive (when DC power supply is connected to the positive terminal of the power supply)

4.10 Schematic diagram of connection with PC

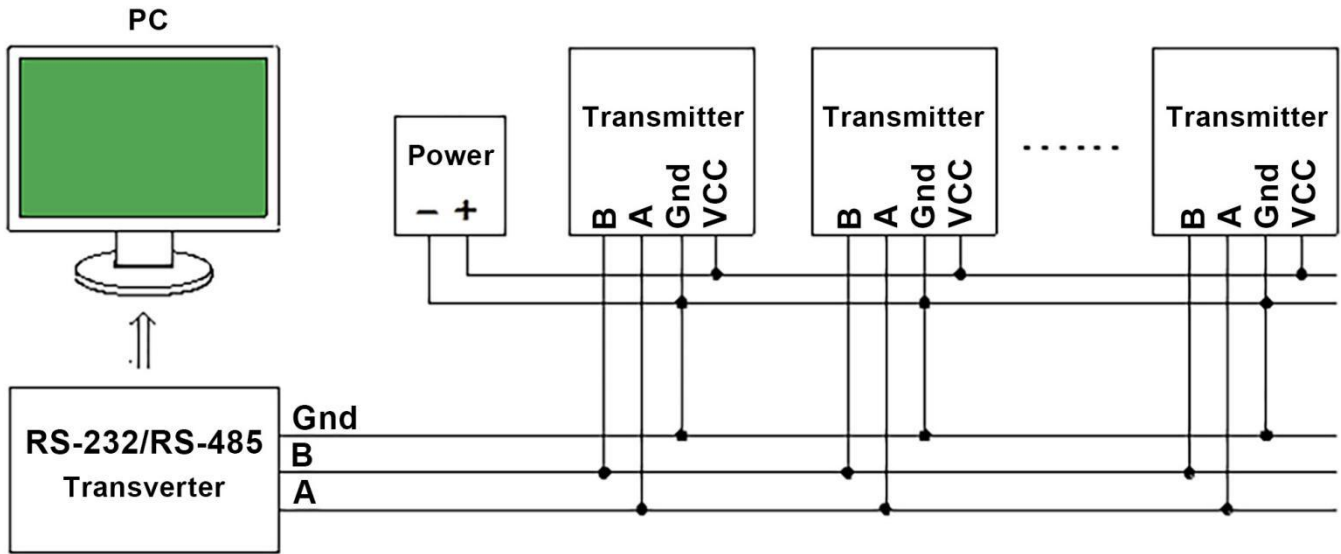

Note:

When setting up a RS485 network, pay attention to the RS485 grounding treatment to eliminate the common mode voltage. Suggest to connect the common ground of each sensor together, and then connect it to the ground wire of the RS-232/RS-485 transverter.

To connect, you can use the shielding layer of the shielded wire as the ground wire.

4.11 Temperature and humidity update time

Temperature and humidity update time	Update temperature and humidity data every 30s
--------------------------------------	--

5.DIP switch and address code

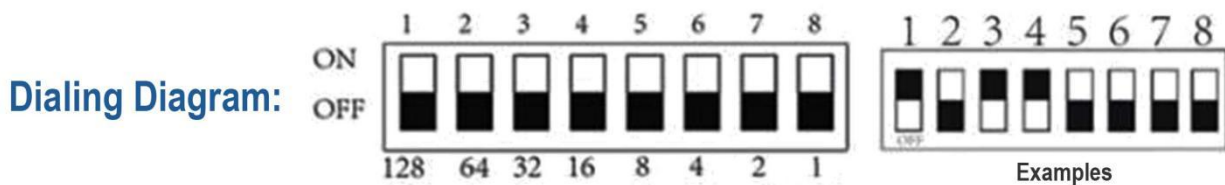

Note: The above picture is a schematic diagram of the DIP switch. The DIP switch has 8 DIP positions. The corresponding numbers from 1 to 8 are 128, 64, 32, 16, 8, 4, 2, 1, and these values are added together as the address code. As shown in the figure above, bits 1, 3, and 4 are in the ON position, so the address code is $128+32+16=176$, that is, the address code is 176



First step



Second step

The above figure is a schematic diagram of the correct steps to open the DIP switch. The first step: use a screwdriver to unscrew the four corner screws in the figure, as shown in the figure above.

Step 2: Turn on the DIP switch to set the address, as shown in the second step above, the part circled on the left is the power communication interface. The connection method has been explained in the electrical connection in 4.9, please read it carefully

note! You can specify when ordering, and we will preset it for you.

6 Protocol

For the Modbus-RTU protocol, please refer to the relevant information, here is only a brief introduction.

6.1 Data frame format

Start bit	Data bit	Parity bit	Stop bit
1	8	0	1

Note:

The above is the default format of the sensor. If you need other formats, please specify when ordering.

6.2 RTU message frame format

THT-02 follows the RTU information frame protocol. In order to ensure the integrity of the information frame, a pause time of 3.5 characters or more is required at the beginning and end of each information frame (T1-T2-T3-T4, this time can be based on the wave Calculated by special rate), each byte of the information frame needs to be transmitted continuously. If there is a pause time greater than 1.5 characters, the sensor will treat it as invalid information and will not respond.

6.3 Information frame format

Start	address	function code	Data area	CRC check	end
T1-T2-T3-T4	1byte	1byte	N byte	2byte	T1-T2-T3-T4

6.4 Register definition

Register Address	Meaning	Description	Read and write
0	Temperature	The unit is 0.1 degree, MSB First, complement format, 7FFF H means the sensor is abnormal	Read only
1	Relative humidity	The unit is 0.1%, MSB First, complement format, 7FFF H means the sensor is abnormal	Read only
2	Reserved 1		Read only
3	Reserved 2		Read only
4	Address code	Set by DIP switch	Read only
5	Baud rate	Support 4800、9600	Can read and write
6	Hardware version		Read only
7	Software version		Read only

6.5 Address setting

You can specify when ordering, we will preset it for you, or you can modify it by yourself through the dial switch

6.6 Baud rate setting

You can specify when ordering, we will preset it for you, or you can modify it by yourself through the serial port assistant.

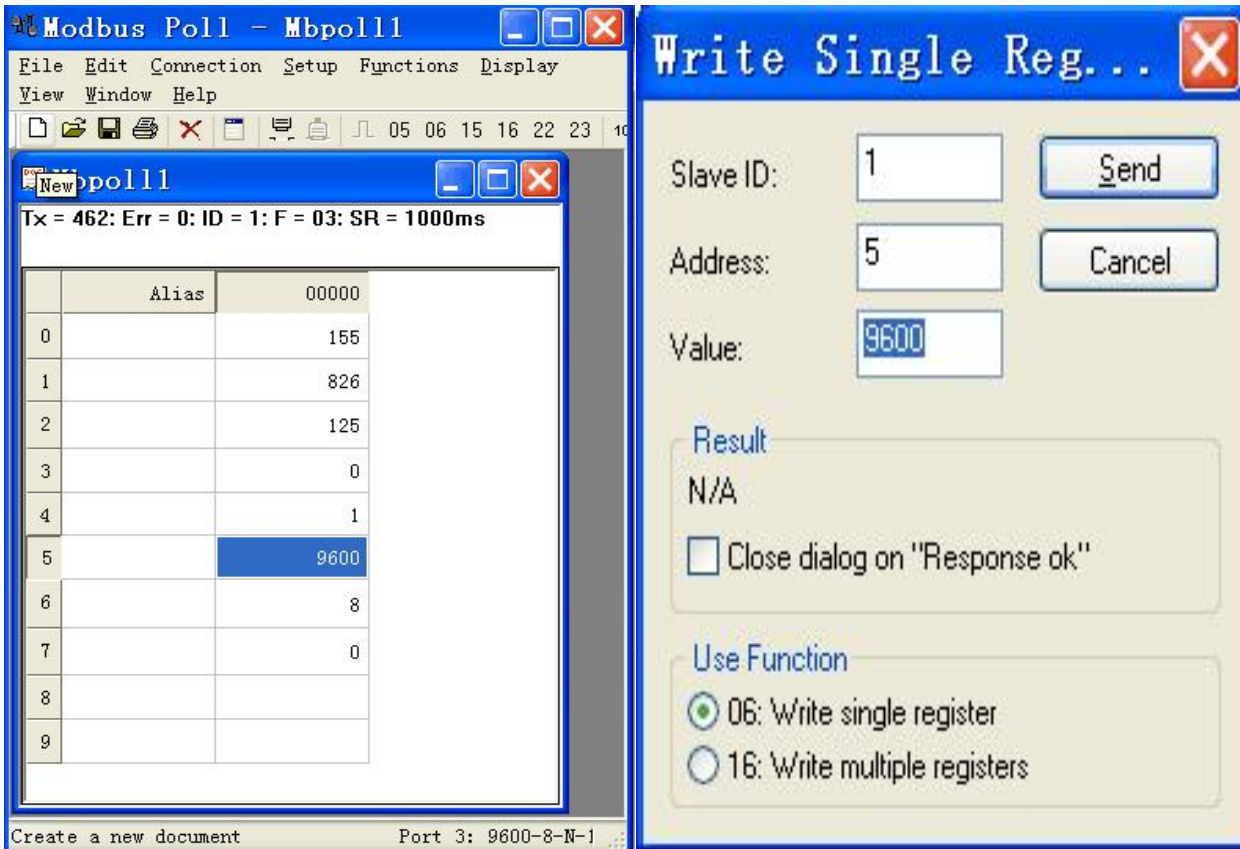

6.7 Host reads sensor information (function code 03)

The sensor allows the host to use the function code 03 to read the temperature and humidity measurement value of the sensor and other information. The information frame format of the 03 code is as follows:

Host request information frame

Field Description	Example
Slave address	01
Function code	03
Register address high byte	00
Register address low byte	00
High byte of query quantity	00
Low byte of query quantity	08
CRC check code low byte	44
CRC check code high byte	0C

Sensor response information frame

Field Description	Example
Slave address	01
Function code	03
Return the number of bytes	10
Temperature data high byte	00
Temperature data low byte	FA
Humidity data high byte	02
Low byte of humidity data	58
1 high byte reserved	00
1 low byte reserved	00
2 high byte reserved	00
2 low byte reserved	00
Address code high byte	00
Address code low byte	01
Baud rate high byte	25
Baud rate low byte	80
Hardware version high byte	06
Hardware version low byte	00
Software version high byte	00

Software version low byte	0A
CRC check code low byte	D4
CRC check code high byte	64

Data analysis

Temperature = 00FAH = 250 / 10 = 25.0°C ;

Humidity = 0258H = 600 / 10 = 60.0%RH;

Reserved 1 = 0000H;

Reserved 2 = 0000H;

Address code = 0001H = 1;

Baud rate = 2580H = 9600;

Hardware version = 0600H;

Software version = 000AH = 10 = V1.0;

Note! If users only want to read the temperature and humidity or other registers, they only need to read the corresponding registers.

6.8 Host setting sensor information (function code 06)

This machine can currently set the baud rate (register address is 0005H), and the message frame format is as follows:

Host request information frame

Field description	Example
Slave address	01
Function code	06
Register address high byte	00
Register address low byte	05
Set value high byte	25
Set value low byte	80
CRC check code low byte	82
CRC check code high byte	FB

Sensor response information frame

Field description	Example
Slave address	01
Function code	06
Register address high byte	00
Register address low byte	05
Set value high byte	25
Set value low byte	80
CRC check code low byte	82
CRC check code high byte	FB

Data analysis: Set the baud rate to 9600

6.9 Abnormal response

When the host sends request information to the sensor, various errors may occur. At this time, the sensor sets the highest position of the function code to 1, and then returns an error code. The host can determine whether an error has occurred by detecting whether the highest bit of the function code is 1.

Return format

Slave address	Function code	error code	CRC check
1 byte	1 byte	1 byte	2 byte

Error code

- 01: Illegal function code
- 02: Illegal data address
- 03: Illegal data value

6.10 CRC check code

RTU mode uses CRC-16 check, the check code occupies 2 bytes, if the check code is wrong, the sensor will ignore the host's request and not respond.

The calculation method of CRC-16 check code is as follows:

- ① Preset a 16-bit register as hexadecimal FFFF, call this register CRC register;
- ② XOR the first 8-bit binary data (the first byte of the information frame) with the lower 8 bits of the 16-bit CRC register, and place the result in the CRC register;
- ③ Shift the content of the CRC register one bit to the right (toward the low bit) and fill the highest bit with 0, check the right shift out position after shift;
- ④ If the shifted out bit is 0, repeat step ③ (shift one bit to the right again), if the shifted out bit is 1, the CRC register is XORed with the polynomial A001 (1010 0000 0000 0001);
- ⑤ Repeat steps ③ and ④ until the right shift is 8 times, so that the entire 8-bit data has been processed;
- ⑥ Repeat steps ② to step ⑤ to process the next byte of the message frame;
- ⑦ After calculating all the bytes of the information frame according to the above steps, the content of the CRC register obtained is: 16-bit CRC check code.

7 Dimensions (unit: mm)

